

The DSCV-SA valve: a modern solution to steam conditioning

Mark Wheat, Business Unit Manager for SPX, outlines how technical innovation and leading edge design produced the world's leading steam turbine bypass valve

The DSCV-SA (Direct Steam Converting Valve - Steam Atomization) from SPX is designed for unprecedented operational reliability and eliminates potential risks associated with substandard designs during plant start-up, shutdown and turbine trips. As a result, the DSCV-SA is at the forefront of modern thermodynamic engineering in steam conditioning.

Key to the DSCV-SA's performance are a number of unique technical innovations developed by SPX following extensive consultation with customers in the power generation sector.

The first of these unique innovations is high-pressure balance. Unlike conventional turbine bypass valves, the DSCV-SA is designed to use high-pressure balance rather than low-pressure balance. This eliminates risk of wear, damage or breakage relating to piston rings and balancing systems, which are a major problem with traditional valves.

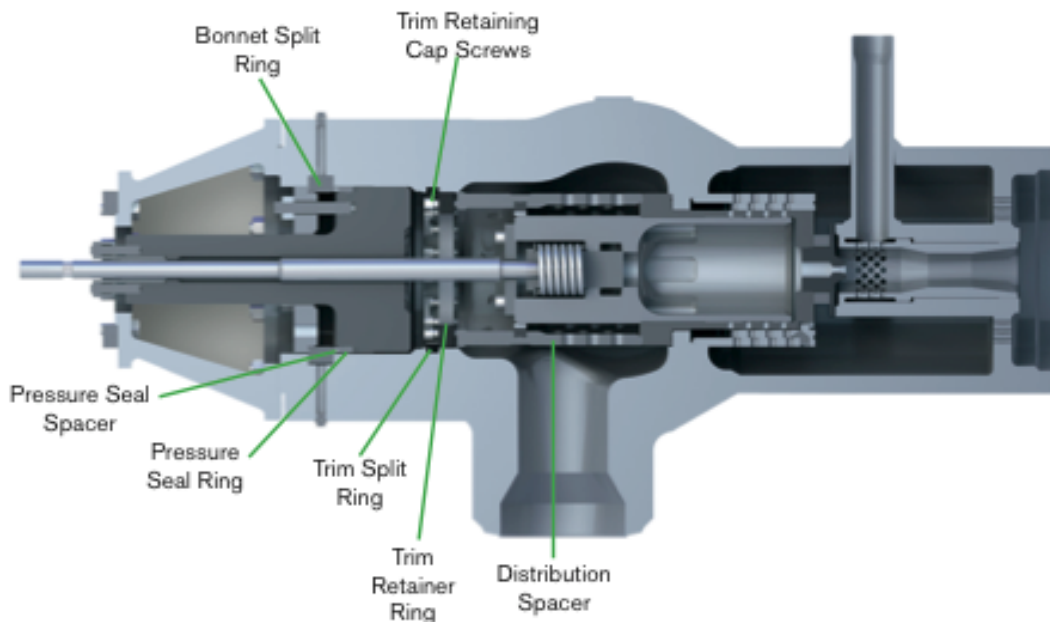

The DSCV-SA turbine bypass valve has evolved over many years to be at the forefront of today's thermodynamic engineering in steam conditioning.

When an open command signal is received, the DSCV-SA actuator retracts and the pilot plug is the first to open. This allows P1 steam to flood through the large pilot plug port to the underside of the main plug which in turn balances it and reduces the actuation thrusts required.

In traditional low-pressure or P2 balancing designs, auxiliary balancing seals such as piston rings and close tolerance sealing surfaces are needed to prevent the high-pressure steam unbalancing the trim. In operation, if these seals or surfaces become worn or damaged, it can unbalance the trim and stem loads can fluctuate dramatically causing the valve to oscillate violently or not open on command.

When the DSCV-SA pilot plug is open, high-pressure inlet steam floods the underside of the main plug and the steam atomizing unit (see the following information on Steam Atomization) operates in preparation of the incoming cooling water from the water control valve. The pilot plug shoulder engages with the underside of the tandem cap of the main plug which then starts to lift and the main seat opens.

As the main plug opens, steam first enters the valve via a heavy duty distribution spacer. The steam passes through the spacer by means of numerous holes evenly positioned around the circumference. This heavy duty distribution spacer is specifically designed to negate any upstream pipework-induced flow disturbance being communicated to the main plug. This is important because long radius bends or isolation valves can be fitted directly to the valve inlet to minimize installation space. The main plug is fully guided by the cage and spacer to ensure complete plug stability through full travel.

After the inlet steam has passed through the distribution spacer, it then travels through the main seat area to the underside of the main plug via large feed ports. With the main plug lifted, the pressure reducing ports of the cage now open to allow the steam to be pressure reduced in a controlled manner. As the main plug opens further, more pressure reducing ports are exposed and the steam flow rate increases.

Another unique innovation associated with the DSCV-SA is steam atomization. Steam atomization is a technology that has significant benefits over mechanically spraying the cooling water via nozzles.

Traditional mechanical spray nozzles - even spring-loaded types - are limited in their turndown. This is because the water atomization and spray pattern degrade as the water flow rate and available pressure differential reduces. As the water demand reduces, the spray water control valve closes and the spray valve trim absorbs the water pressure differential leaving little pressure differential for the spray nozzles. This lack of pressure differential at the spray nozzles

does not allow atomization of the spray water, which results in the water pouring into the steam rather than producing a fine atomizing mist.

Mechanical spray nozzles rely on the surrounding steam velocity to provide adequate mixing. When the steam load reduces, so too does the steam velocity and the ability of the mechanical spray nozzles. This effect manifests itself with poor downstream steam temperature control and water 'drop-out' which can be very damaging as cold water can track along the bottom of the inside wall of the downstream pipe whilst un-cooled superheated steam travels along the top and sides. This produces high thermal shocks which can lead to steam header fracture.

With steam atomization however, cooling water is pre-heated, significantly accelerating the evaporation and desuperheating process. Equally important is the finely atomized incoming cooling water. Very fine atomization produces extremely small water droplet sizes with a vastly increased surface area to promote rapid heat transfer. The atomized, pre-heated water is introduced via a combining tube where it is atomized and then passed through a converging – diverging venturi throat section. The hot atomised water exits the atomising head and is rapidly evaporated, cooling the main steam flow. Because this method of water introduction does not rely on surrounding steam velocity or turbulence for effective mixing, it gives very high turndowns - generally in excess of 100:1.

In terms of design, the DSCV-SA has a standard body-to-bonnet joint, up to ANSI 900#, which is bolted and incorporates a fully-enclosed spiral wound gasket made from 300 stainless steel with graphite filler. For pressure ratings above ANSI 900# a pressure seal bonnet closure is employed, which utilizes a graphite sealing ring. The DSCV-SA is available in an almost infinite range of sizes, materials and pressure ratings as each valve is tailored to suit particular customer requests and requirements.

The valve can be fully rated or split rated design and available in standard, special or intermediate classes. Standard classes are available up to and including ANSI 4500# and intermediate and special class designs can be accommodated where required. As the DSCV-SA is usually supplied as a split rated design, this provides the customer with a convenient point for pipe transition for size, rating and material. The DSCV-SA is of a two-part construction and therefore virtually any configuration can be met to satisfy client requirements.

Importantly, the DSCV-SA is not a high maintenance valve. However, the complete trim is a 'Quick-Change' style with no welded in components or large internal threaded parts. The whole

trim assembly is held in compression by either a compression ring or the bonnet. By simply removing the compression ring or bonnet, the whole trim merely slides out the top of the valve. Therefore in-situ maintenance, if required, should be both expeditious and uncomplicated with no need for specialised tooling or training.

Modern steam turbine bypass systems must be able to react and modulate very quickly under emergency conditions such as a turbine trip. Stroking speeds of less than one second may be required and as a result, the DSCV-SA can be supplied with either pneumatic or hydraulic actuation to meet this critical requirement.

Due to its unique innovations and fundamental attention to design and usability, hundreds of DSCV-SA valves are already in use worldwide in oil, gas, biomass and coal-fired power plants, refineries, paper mills and many other industrial activities which rely on steam generation for their processes.

About SPX

The SPX Flow Technology segment designs, manufactures and installs highly engineered solutions used to process, blend, meter and transport fluids, in addition to solutions for air and gas filtration and dehydration. The segment supports global food and beverage, dairy, pharmaceutical, oil and gas, energy, and industrial markets. SPX (NYSE: SPW) is a global Fortune 500 multi-industry manufacturing company. With headquarters in Charlotte, N.C., SPX has 15,500 employees in more than 35 countries worldwide. Visit www.spx.com.